

**RS-485/422/232 to Fiber Converter  
DB9/Terminal Block to ST Fiber  
EX-9541/42 User's Manual**

**1. Overview**

RS-485/422/232 to fiber optic converter is used to extend distance up to 2Km over the multi-mode fiber or up to 20Km over the single-mode one. The converter is equipped with multiple interface circuit such as RS-232, RS-422 and RS-485 2/4-wire. This converter can be used as a standalone unit or as a slide-in module to the 19" converter rack (up to 10 units) for use at a central wiring closet.

**2. Checklist**

Before you start installing the Converter, verify that the package contains the following:

- The RS-485/422/232 to Fiber Converter
- AC-DC Power Adapter
- This User's Manual

Please notify your sales representative immediately if any of the aforementioned items is missing or damaged.

**3. Installing the Converter**

Note: The Media Converter is hot-swappable.

⇒ Wear a grounding device for electrostatic discharge.

**For as a standalone unit:**

- ⇒ Verify that the AC-DC adapter conforms to your country AC power requirement and then inserts the power plug.
- ⇒ Install the media cable for network connection.

**For as a slide-in unit:**

- ⇒ Verify that the media converter is the right model and conforms to the chassis slot. The Media Converter and Rack are built to match each other in dimensions, DC jack, DC receptacle and power safety.
- ⇒ Locate +5VDC power jack on converter back, carefully slide in and plug to 19" rack +5VDC power receptacle.
- ⇒ Install the media cable for network connection. The Tx, Rx fiber and copper cable must be paired at both ends. Please ensure that the copper cable and its voltage polarity match the device requirement for 4-wire or 2-wire connection.

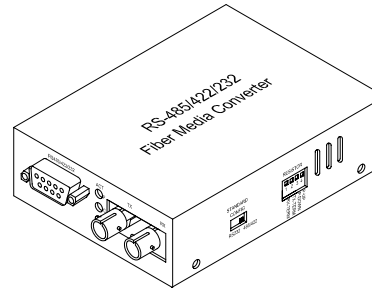

Fig. 1 RS-485/422/232 DB9 to Fiber Converter

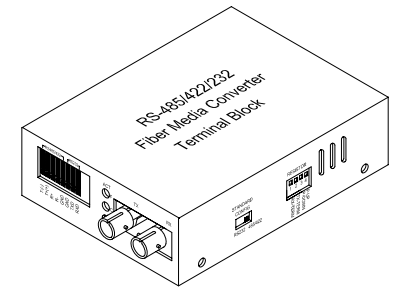

Fig. 3 RS-485/422/232 Terminal Block to Fiber Converter

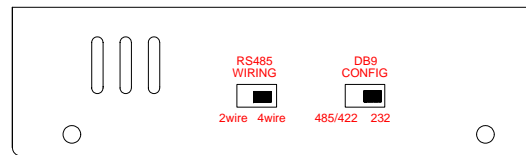

Fig. 2 DB9 to Fiber Converter Side Panel

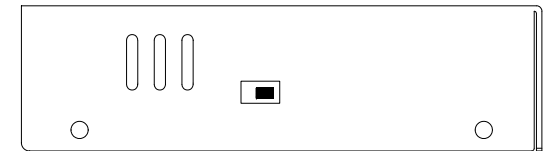

Fig. 4 Terminal Block to Fiber Converter Side Panel

#### 4. Switches Setting, Terminal Block, DB9

- **STANDARD CONFIG (copper protocol) SW**  
Copper port/cable protocol: RS232 or RS485/422 selection.  
RS232 : RS-232 protocol/connection, **default**.  
485/422: RS485/422 protocol/connection.
- **RS485 WIRING (RS485 2/4-wire) SW**  
RS485 wires: 2 or 4-wire selection.  
2-wire: 2-wire (Copper) at half-duplex mode.  
4-wire: 4-wire (Copper) at full-duplex mode, **default**.  
"RS485/4-wire" is also used for RS422/4-wire connection.
- **DB9 CONFIG (DB9 connector model only) SW**  
232 : RS232/DB9 connection, **default**.  
485/422: RS485/422 via DB9 port and setup with  
"STANDARD CONFIG" SW accordingly.

For DB9 model and port connection, the available connections by the three SW setting are:

Protocol & Connection	STANDARD CONFIG SW	DB9 CONFIG SW	RS-485 WIRING SW
RS-232	RS-232	RS-232	Don't care
RS-485 4 wire	RS-485/422	RS-485/422	4 wire
RS-485 2 wire	RS-485/422	RS-485/422	2 wire
RS-422	RS-485/422	RS-485/422	4 wire

Note:

Terminal block model is not equipped with the "DB9 CONFIG" switch, the available connections by the two SW setting are:

Protocol & Connection	STANDARD CONFIG SW	DB9 CONFIG SW	RS-485 WIRING SW
RS-232	RS-232	NA	Don't care
RS-485 4 wire	RS-485/422	NA	4 wire
RS-485 2 wire	RS-485/422	NA	2 wire
RS-422	RS-485/422	NA	4 wire

- **RESISTOR SW**  
(Terminal Resistor/Pull-up and Pull-Down Res. Setting)

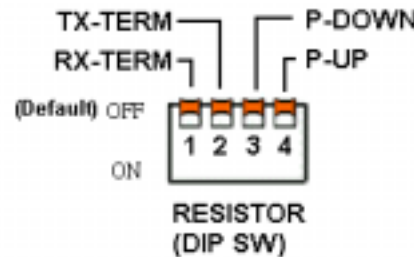

RESISTOR SW is used for RS485/422 protocol/connection, and will take effect when STANDARD CONFIG is at "485/422".

- The RESISTOR SW default: 1, 2, 3, 4. All are at "OFF"
- RX-TERM ON : Enables 130 Ω terminator on RX
- TX-TERM ON : Enables 130 Ω terminator on TX
- P-DOWN ON : Enables 1k Ω pull down on RS422/RS485(4-wire) TX- or RS485(2-wire)TX/RX-
- P-UP ON : Enables 1k ohm pull up on RS422/485(4-wire) TX+ or RS485(2-wire)TX/RX+

#### Warning:

- The termination and P-UP, P-DOWN resistors are set up, which depends on the RS485/422 network configuration.
- Ensure that the copper cable and its voltage polarity match the device requirement for 4-wire or 2-wire connection.
- Improper termination and network configuration will render the devices to work poorly.

- **Terminal Block for Copper Wires**  
RS485/422/232 protocol/connection via Terminal Block

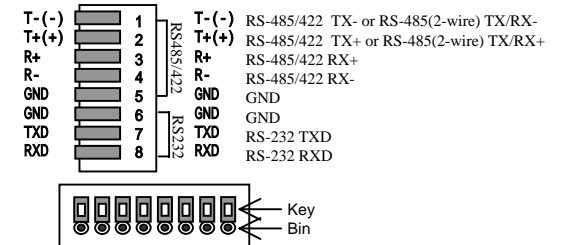

Each bin of Terminal Block is equipped with a key. Push and hold the key to release Terminal Block when plugging in or removing the copper wire.

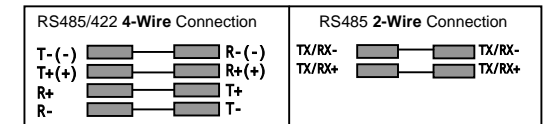

- **DB9 Connector for Copper Wires**  
RS232 protocol/connection via DB9

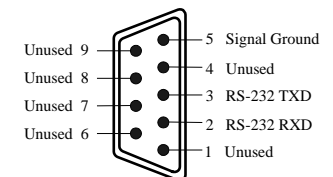

#### RS-232 Cable Connection via DB9

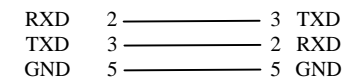

### RS485/422 protocol/connection via DB9

If you use DB9 for RS485/422 cable connection, the Pin definition and assignment is as follows:

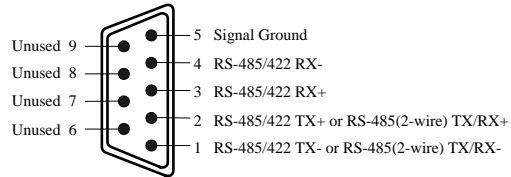

You may configure RESISTOR SW for proper termination or P-UP, P-DOWN resistors in the network connection.

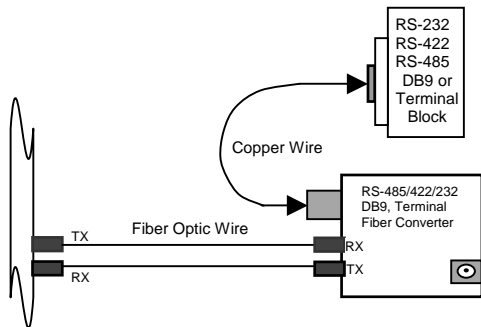

Fig. 5 RS-485/422/232 Fiber Optic Network Connection

### 5. LED Description

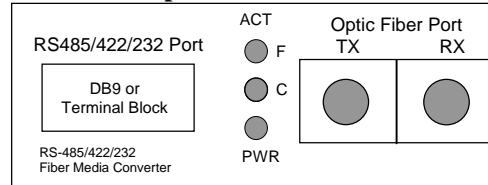

Fig. 6 RS-485/422/232 to ST Fiber Converter Front Panel

LED	Color	Function
F (FX ACT)	Green	Blinks when fiber data is received
C (Copper ACT)	Green	Blinks when Copper data is received
PWR	Green	Lit when +5V power is coming up

### 6. DC Jack and AC-DC Power Adapter

The DC jack's central post is 2.5mm wide and conforms to the DC receptacle(2.5mm).

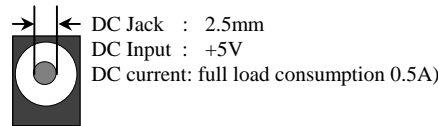

Fig. 7 DC+5V Input Jack and Dimension

AC-DC adapter using different AC input voltages is available for different areas.

AC Input:	North America	120VAC 60Hz
	Europe	230VAC 50Hz
	U.K.	230VAC 50Hz
	South Africa	240VAC 50Hz
	Australia	240VAC 50Hz
	Japan	100VAC 50/60Hz
DC Output:	5VDC @ 1.0A	

### 7. Fiber Technical Specifications

- Standards : TIA/EIA-232(ITU-T V.28)  
TIA/EIA-422(ITU-T V.11)  
TIA/EIA-485(ISO/IEC8284)

#### \* Model Description :

Model	Interface	Fiber Type	$\lambda$ (nm)	Distance
EX9541	DB9(male)	ST multi-mode	820	2Km
	Terminal	ST multi-mode	820	2Km
EX-9542	DB9(male)	ST single-mode	1310	20Km
	Terminal	ST single-mode	1310	20Km

\* Single-mode model is by request

#### \* Data Transfer Rate and Maximum Cable Distance

Connection	Max. Rate Bps	Max. Distance
RS-232	115.2K	15m (50ft)
RS-422/485	90K	1220m (4000ft)
RS-422/485	500K	92m (300ft)
MM Fiber	*	2Km
SM Fiber	*	20Km

\* Fiber Optic Rate depends on Copper Port speed

- Copper Wires : 24 to 22 AWG gauge  
Attenuation 20dB/1000ft @ 10MHz  
Differential Impedance 100 $\Omega$  @ 10MHz
- Fiber Cable :  
50/125, 62.5/125, or 100/140 $\mu$ m multi-mode  
8.3/125, 8.7/125, 9/125 or 10/125 $\mu$ m single mode
- Data Transfer Rate : up to 115.2Kbps (RS-232)  
up to 500Kbps (RS-485/422)
- Power Requirement : 1A@+5VDC
- Ambient Temperature: 0° to 50°C
- Humidity : 5% to 90%
- Dimensions : 26.2(H) × 70.3(W) × 94(D) mm
- Complies with FCC Part 15 Class B and CE Mark

Note:

For connecting this device to Router, Bridge or Switch, please refer to the corresponding device's Technical Manual.